

Steambath Generator

Model: SM-11

The Steamist “SM” Generator operates with one or two controls appropriately located inside and/or outside the steamroom. It’s small enough in size to be tucked away using very little space in a vanity, closet, basement, or an insulated attic, but large enough to provide steam for most residential baths.

The Steamist “SM” Steambath Generator comes factory assembled, carefully wired and tested.

NOTE: The SMC-120, SMC-150, TC-125, TC-150, TC-110, TC-135, DSC-425, and DSP Controls are designed to work with all Steamist “SM” Generators.

1. Pre-Installation

- Proper electrical supply (208 or 240 Volt): See rating label on Steam Generator and Chart on back page. Determine proper size of wire, voltage, amperage, and phase for the Steam Generator. 90°C copper wire is required for generator connection.
- Dedicated overcurrent protection device, such as an in-line fuse/circuit breaker required: Fuse/circuit breaker to be installed must be sized in accordance with chart on back page. Do NOT install a GFI (Ground Fault Interrupter) to this equipment (per article 210-8 in the National Electric Code).
- Route power supply cable to the location where the Steam Generator will be installed (before walls are closed).

2. Electrical Rough-in

- At this time read through the installation instructions for the selected control(s).
- Route appropriate power cable to the location the Steam Generator will be installed. If receptacle is desired, mount the box for the receptacle near the location of the Steam Generator.

NOTE: The plug and receptacle require a rating of no less than 250V and proper amperage. Refer to chart on page 4 for amperage rating.

After the walls are complete, the Steam Generator and Control can be wired.

3. Steam Generator Electrical Installation

WARNING: All power to the Steam Generator must be turned off.

- Remove the four screws holding the electrical access cover and remove cover.
- Locate the supply line knockout. Mount proper strain

relief into knockout hole (see Figure 2: Internal Electrical Connections).

- Strip back power cable’s outer insulation jacket eight inches and insert into Steam Generator. Strip back insulation ½” from the three (3) incoming wires (two power and one ground).
- Connect incoming ground wire to floating green pigtail labeled “GND.”

CAUTION: Be sure the ground wire does not come in contact with a live electrical part.

- Connect incoming power to floating black pigtail leads labeled “L1” and “L2” (see Figure 2: Internal Electrical Connections).
- The Steam Generator is ready for operation once the installation of the controls is completed (refer to separate Installation and Operating Instructions).

4. Optional Auto Drain Valve Connection

- Open knockout for Auto Drain Valve conduit connection.
- Route flexible conduit from valve to knockout and secure.
- Connect two wires from valve to the two place terminal strip provided (see figure 2).

Figure 1 - Steam Generator

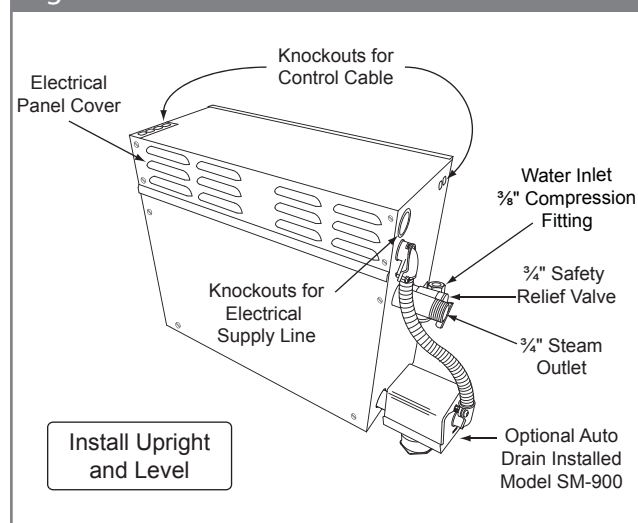

WARNING: Elderly persons, pregnant women, or those suffering from heart disease, high blood pressure, diabetes, or who are otherwise not in good health, do not use this device unless directed to do so by a physician. Also, do not use steambath while under the influence of alcohol. For additional Important Safety Information, please see a separate instruction Pub. No. 199.

IMPORTANT: The warranty of this product is voided if it is used in a commercial application or for anything other than a residential steambath installation. All electrical connections must be performed by a licensed electrician in accordance with Local and National Electric Codes. This product is not intended for use with Home Automation systems.

Before starting, insure that the conditions of the following checklist have been met:

- The proper size Steam Generator has been selected by using the sizing page in the "Full Line Brochure," "Pricing Guide," or "The Generator Sizing Guide" in the Residential Systems/Steambath Product Information section of the Steamist website - www.steamist.com.
- CAUTION:** An improperly sized Steam Generator will NOT produce the amount of steam necessary to reach selected temperature.
- The proper voltage Steam Generator has been selected (i.e., 208V or 240V). A 208V Generator operating on 240V will damage the heating element, and a 240V Generator operating on 208V will result in a 25% loss of power.
- The Steam Generator is installed in an upright position.
- The proper sized 90°C copper wire and circuit breaker have been used.
- The circuit breaker is NOT a GFI (Ground Fault Interrupter) type.
- The Steam Generator is properly grounded.
- The circuit breaker or disconnect switch is on.
- Water supply is open to the Steam Generator.

Figure 2 - Major Electrical Components

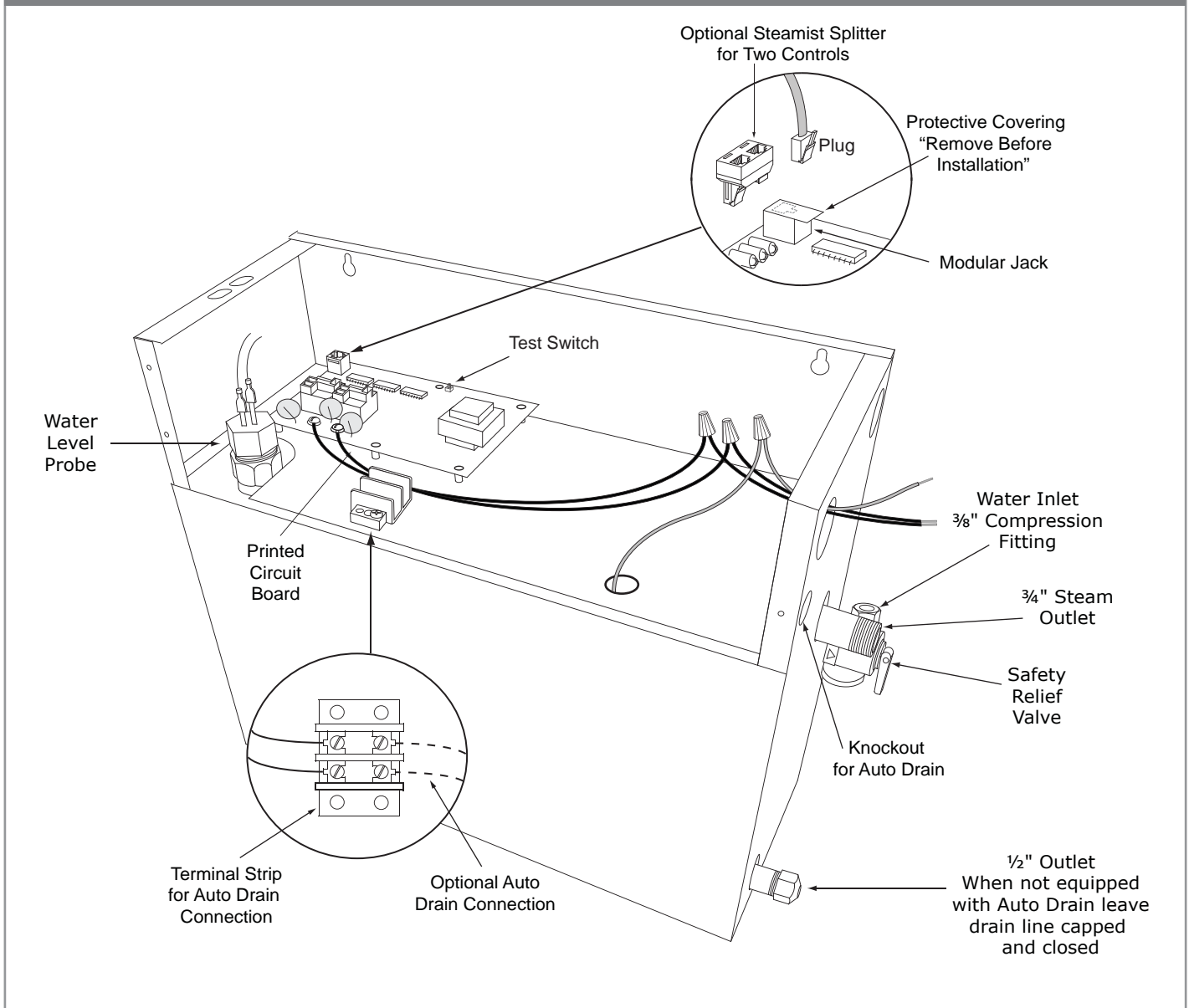

Figure 3 - Typical Installation

Model: SM-11

The Electrical Instructions must be given to the homeowner for future use.

NOTE: Unit must be wired with 90°C copper wire in a suitable raceway, or, if local codes allow, provide twist lock plug on a 90°C copper wire cord from generator to a 250V 2-pole, 3-wire grounding receptacle (amperage rating as required).

SMC-120 or TC-125
Auxiliary Outside
Control

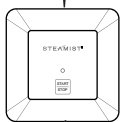

Control Cable
Route from
Control to Steam
Generator in a
3/4" conduit.

Appropriately
fuse protected
208/240V field
wiring to Steam
Generator.

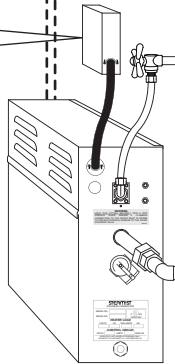

SMC-150 or TC-150
Control **MUST** be
installed inside the
steam room.

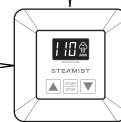

Inside Installation
Control should be mounted four feet from the floor. Select a location convenient to the bather but not in a direct line of Shower or Body Sprays and not directly above the Steamhead.

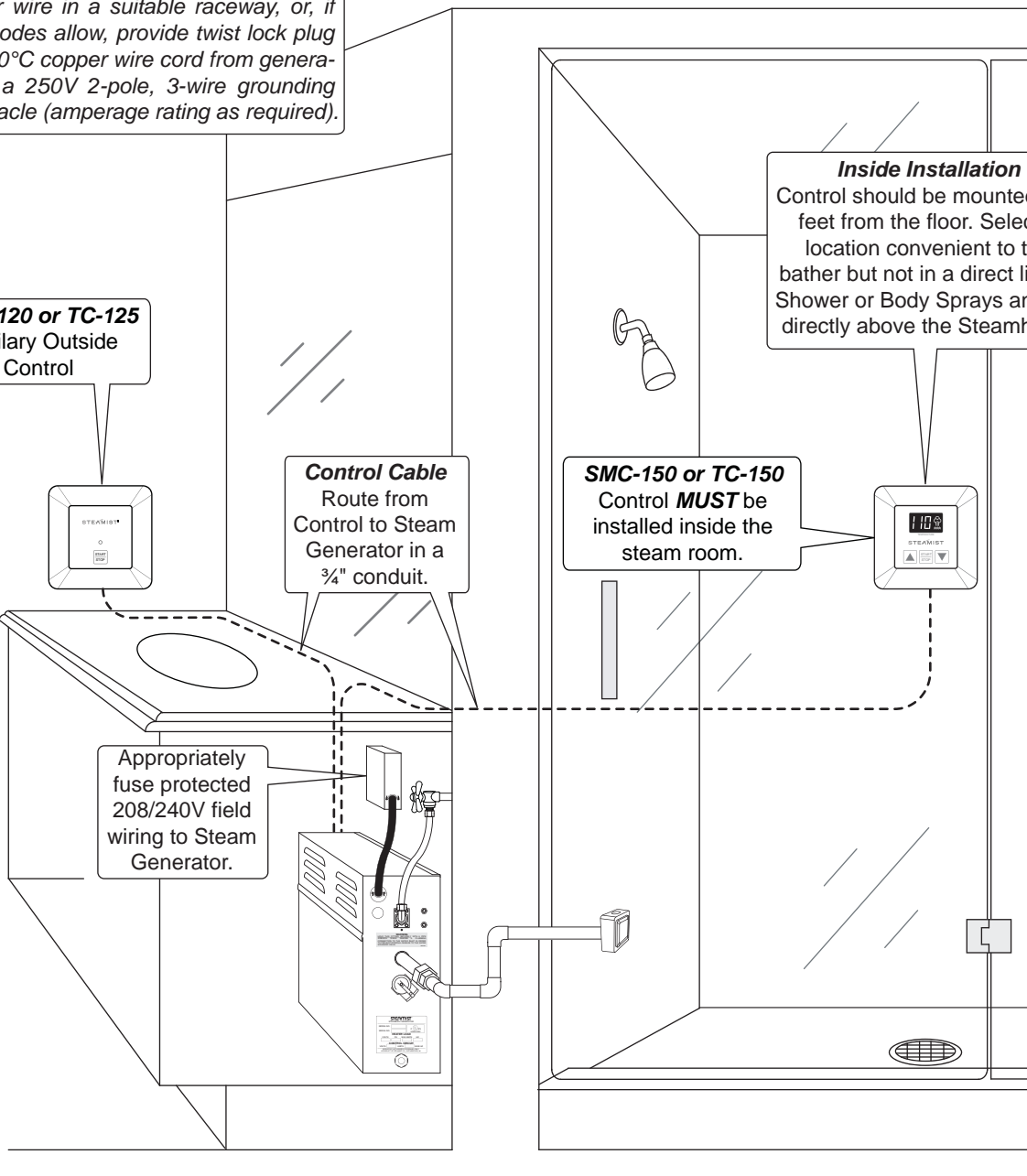

IMPORTANT: Run the Control Cable through a 3/4" conduit. Remove protective cap when making the final connection to Control.

240/208 Volt Single Phase Schematic

Model: SM-11

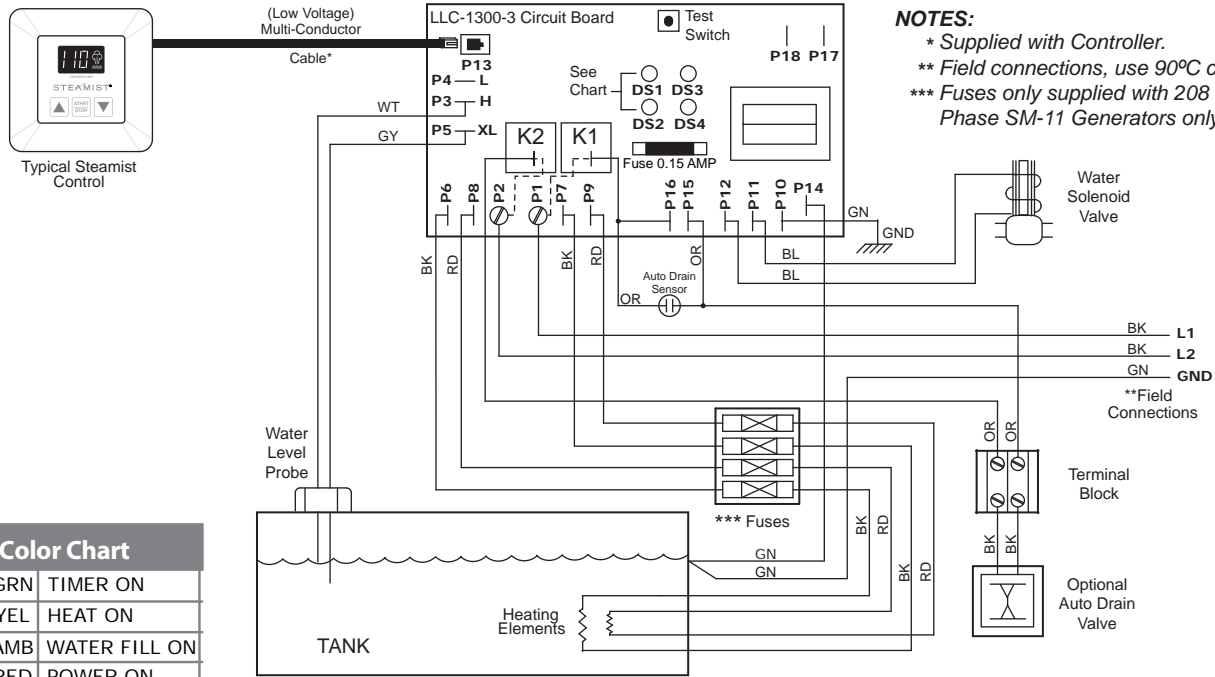

- NOTES:**
- * Supplied with Controller.
 - ** Field connections, use 90°C copper wire
 - *** Fuses only supplied with 208 Volt Single Phase SM-11 Generators only.

LED Color Chart

DS1	GRN	TIMER ON
DS2	YEL	HEAT ON
DS3	AMB	WATER FILL ON
DS4	RED	POWER ON

240/208 Three Phase Schematic

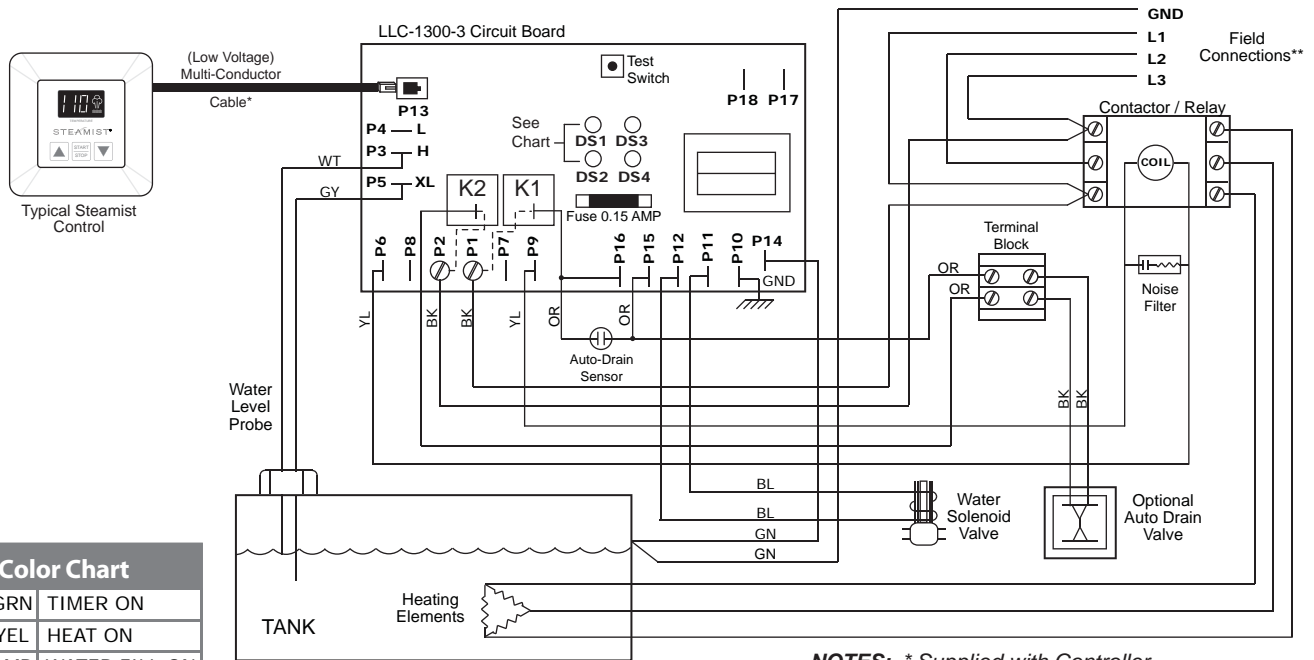

- NOTES:**
- * Supplied with Controller.
 - ** Field connections, use 90°C copper wire

LED Color Chart

DS1	GRN	TIMER ON
DS2	YEL	HEAT ON
DS3	AMB	WATER FILL ON
DS4	RED	POWER ON

Specification Chart

Model No.	Max. Cu. Ft. For Area Up To	KW	Volt	Phase	Amps	Line Fuse
SM-11	500	11	240	1	46	60
			208	1	53	70
			240	3	27	40
			208	3	31	40

90°C copper wire is required for generator connection. Installation shall be in accordance with NEC and local electrical codes.